

产品尺寸图 (DIMENSION)

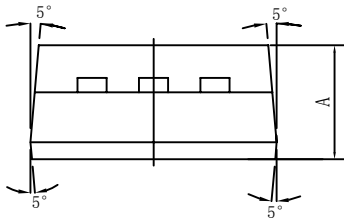
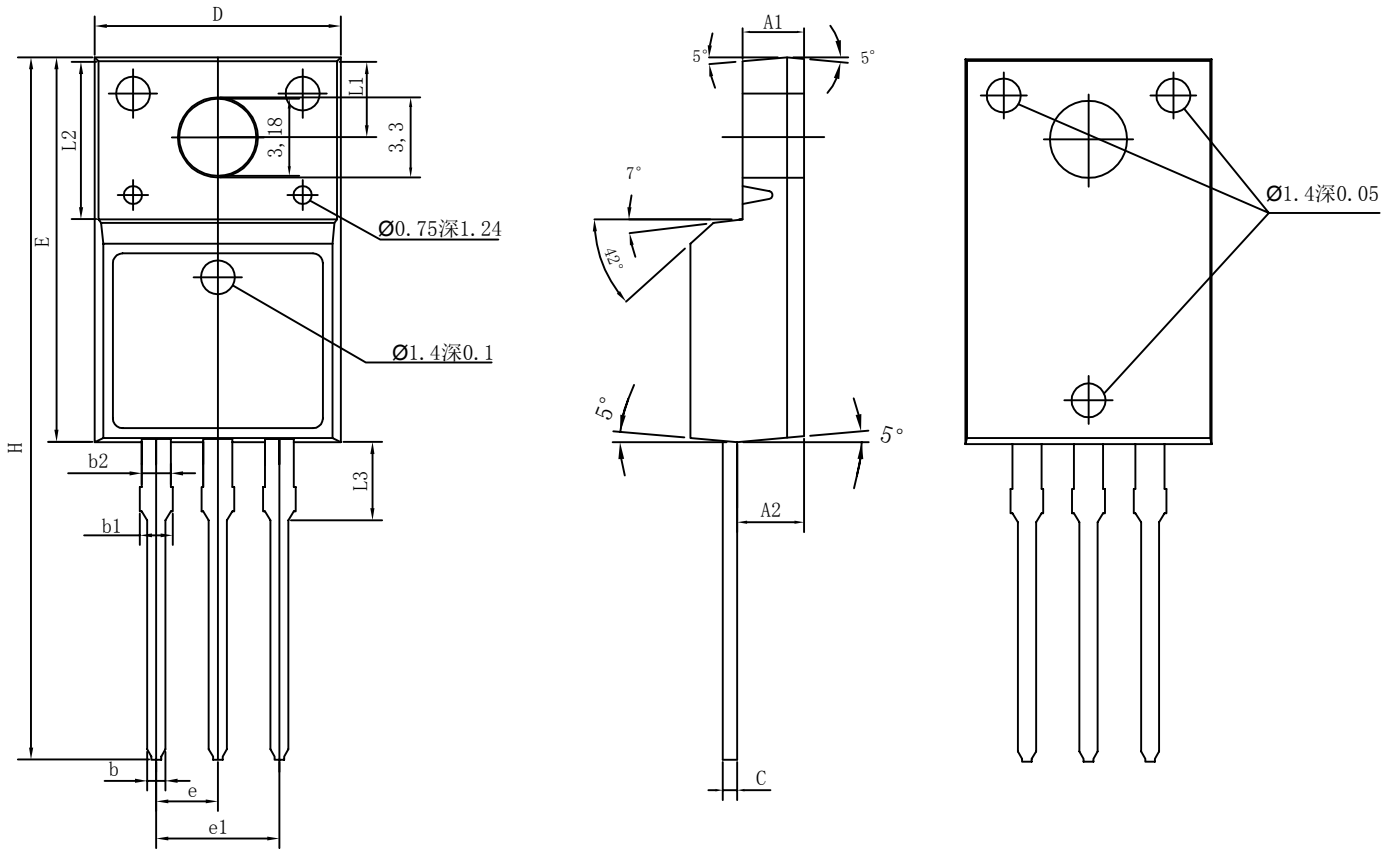

symbol	Dimensions In Millimeters			Dimensions In Inches		
	Min	Nom	Max	Min	Nom	Max
A	4.60	4.70	4.80	0.181	0.185	0.186
A1	2.44	2.54	2.64	0.096	0.100	0.103
A2	2.69	2.76	2.83	0.105	0.108	0.111
b	0.70	0.80	0.85	0.027	0.029	0.031
b1	1.20	1.30	1.40	0.047	0.051	0.055
b2	1.10	1.20	1.30	0.043	0.047	0.051
D	9.96	10.16	10.36	0.392	0.400	0.407
E	15.77	15.87	15.97	0.620	0.624	0.628
H	28.57	28.97	29.37	1.125	1.141	1.156
c	0.5	0.60	0.65	0.021	0.023	0.025
e	—	2.54	—	—	0.100	—
e1	5.00	5.08	5.16	0.197	0.200	0.202
L1	3.20	3.30	3.40	0.125	0.129	0.133
L2	6.58	6.68	6.78	0.259	0.262	0.266
L3	3.13	3.23	3.33	0.123	0.127	0.131

FSMC

图名 NAME	TO-220F1		图号 DWG. NO.	DD0036	SH 1 OF 1
材质 MATERIAL	Cu		REV.	C	
单位 UNITS	mm [INCH]	核准 APPROVE	审核 CHECKED	制图 DRAWN	 第三角
日期 DATE	2020. 12. 07				
比例 SCALE	N. T. S.				